

# DM SERIES LAGGING AND COATING LAGGING

For friction drive belt applications



## Hygienic and loadable

A lagging provides an advantage for drum motors, particularly for wet applications and in food processing, with its typical hygienic requirements. A lagging increases the friction between drum motor and conveyor belt, thereby preventing slippage. On top of that, it is resistant to external influences such as oil, fuels, and other chemicals that may be used for cleaning. Depending on the application, different profiles are available: For high volumes of liquid, a longitudinal grooved lagging redirects moisture between belt and motor, a center V-groove provides space for a tracking profile. Laggings are available in cold and hot vulcanization, whereby the latter meets particularly strict hygiene requirements.

**Note:** It is important to incorporate a calculation of belt pull and speed that is adjusted to the greater outer diameter of the drum motor.



# DM SERIES LAGGING AND COATING LAGGING

For friction drive belt applications

## Technical data

<b>Material</b>	Hot or cold-vulcanized NBR, other materials upon request.
<b>Temperature range</b>	-40 bis +120 °C
<b>Shore hardness</b>	65 and 70 ± 5 Shore A

## Versions

### Cold vulcanization

Lagging profile	Color	Features	Shore hardness	Thickness [mm]
Smooth	Black	Oil- and grease-resistant	65 ± 5 Shore A	3; 4
	White	FDA food approved	70 ± 5 Shore A	
Longitudinal grooves	White	FDA food approved	70 ± 5 Shore A	8
Diamond patterned	Black	Oil- and grease-resistant	70 ± 5 Shore A	8

### Hot vulcanization

Lagging profile	Color	Features	Shore hardness	Thickness [mm]
Smooth	Black	Oil- and grease-resistant	65 ± 5 Shore A	2; 3; 4; 5; 6; 8; 10; 12; 14; 16
	White/blue	FDA food approved (EC) No. 1935/2004 approved	70 ± 5 Shore A	
Longitudinal grooves	Black	Oil- and grease-resistant	65 ± 5 Shore A	6; 8; 10; 12; 14; 16
	White/blue	FDA food approved (EC) No. 1935/2004 approved	70 ± 5 Shore A	
Diamond patterned	Black	Oil- and grease-resistant	65 ± 5 Shore A	6; 8; 10; 12; 14; 16
	White/blue	FDA food approved (EC) No. 1935/2004 approved	70 ± 5 Shore A	
V-groove	Black	Oil- and grease-resistant	65 ± 5 Shore A	6; 8; 10; 12; 14; 16
	White/blue	FDA food approved (EC) No. 1935/2004 approved	70 ± 5 Shore A	

# DM SERIES LAGGING AND COATING LAGGING

For friction drive belt applications

## Dimensions

### Smooth

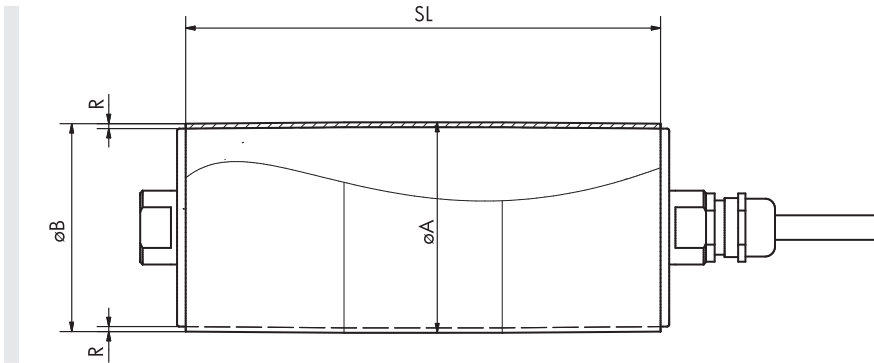

The standard cambers of the lagging are available in the following table.

Drum motor	Ø Tube [mm]	Cold vulcanization			Hot vulcanization		
		Min./max. R [mm]	Ø A [mm]	Ø B [mm]	Min./max. R [mm]	Ø A [mm]	Ø B [mm]
DM 0080	81.5	3	87.5	86.5	2	85.5	84.0
		4	89.5	88.5	6	93.5	92.0
DM 0080 oil-free	81.5				2	85.5	84.5
					16	113.5	112.5
DM 0113	113.5	3	119.5	118	2	117.5	116
		4	121.5	120	16	145.5	144
DM 0113 oil-free	113.5				2	117.5	116
					16	145.5	144
DM 0138	138	3	144	142	2	142	140
		4	146	144	16	170	168
DM 0165	164	3	170	168	2	168	166
		4	172	170	16	196	194
DM 0217	217.5	3	223.5	221.5	2	221.5	219.5
		4	225.5	223.5	16	249.5	247.5

# DM SERIES LAGGING AND COATING LAGGING

For friction drive belt applications

## Diamond patterned

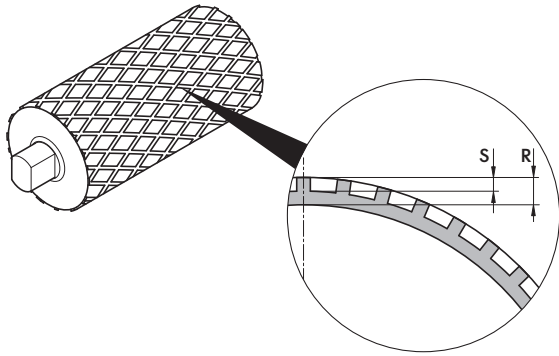

S [mm]	R, cold vulcanization [mm]	R, hot vulcanization [mm]
4	8	6, 8, 10, 12, 14, 16

## V-groove hot vulcanization

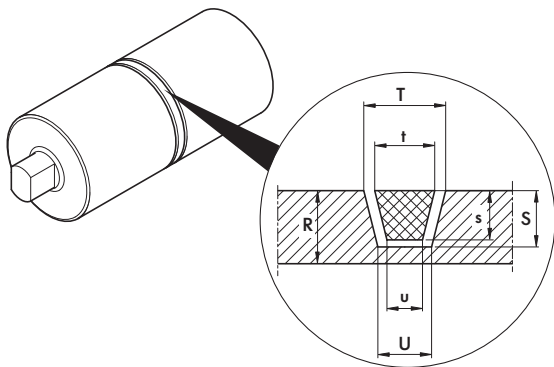

Groove	R Standard [mm]	R Option [mm]	Groove			Belt		
			T [mm]	U [mm]	S [mm]	t [mm]	u [mm]	s [mm]
K6	8	6	10	8	5	6	4	4
K8	8	6	12	8	6	8	5	5
K10	10	8	14	10	7	10	6	6
K13	12	10	17	11	9	13	7.5	8
K15	12	10	19	13	9	15	9.5	8
K17	14	12	21	13	12	17	9.5	11